

Motarized Mousetrap (DesignSpark)

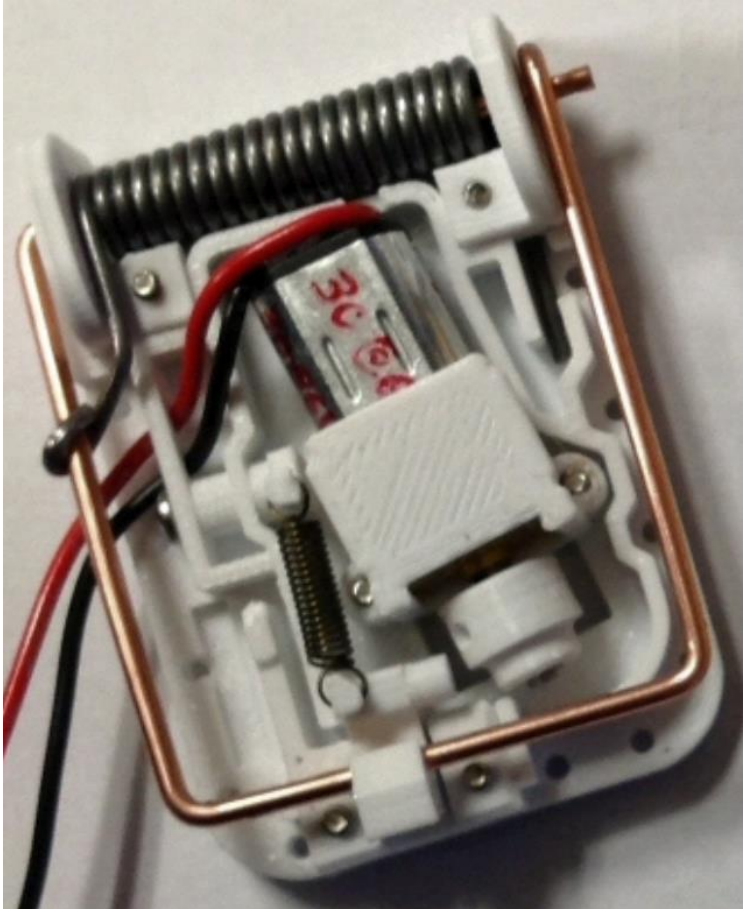

Exploded view (Screws not shown)

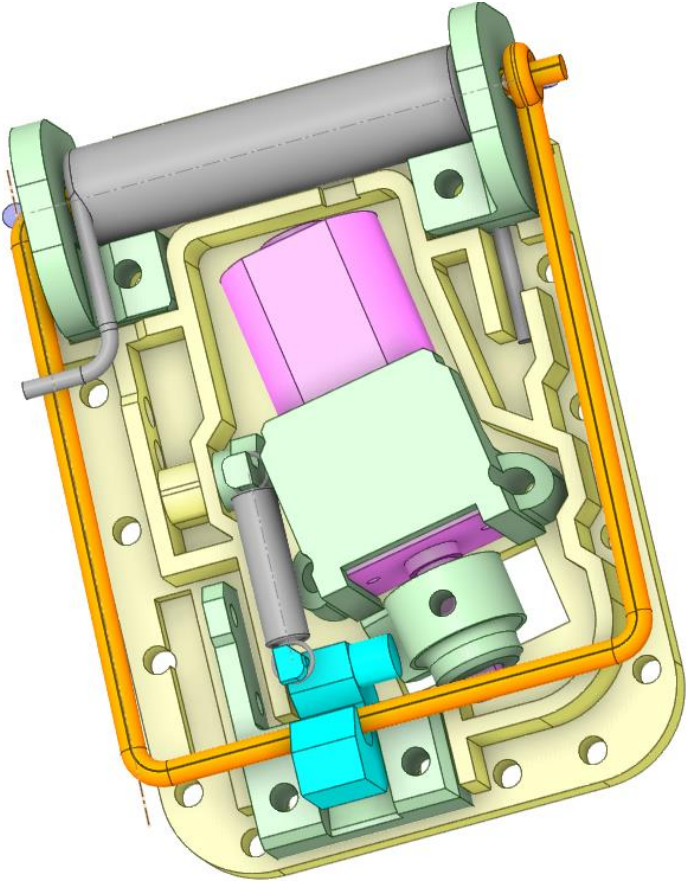
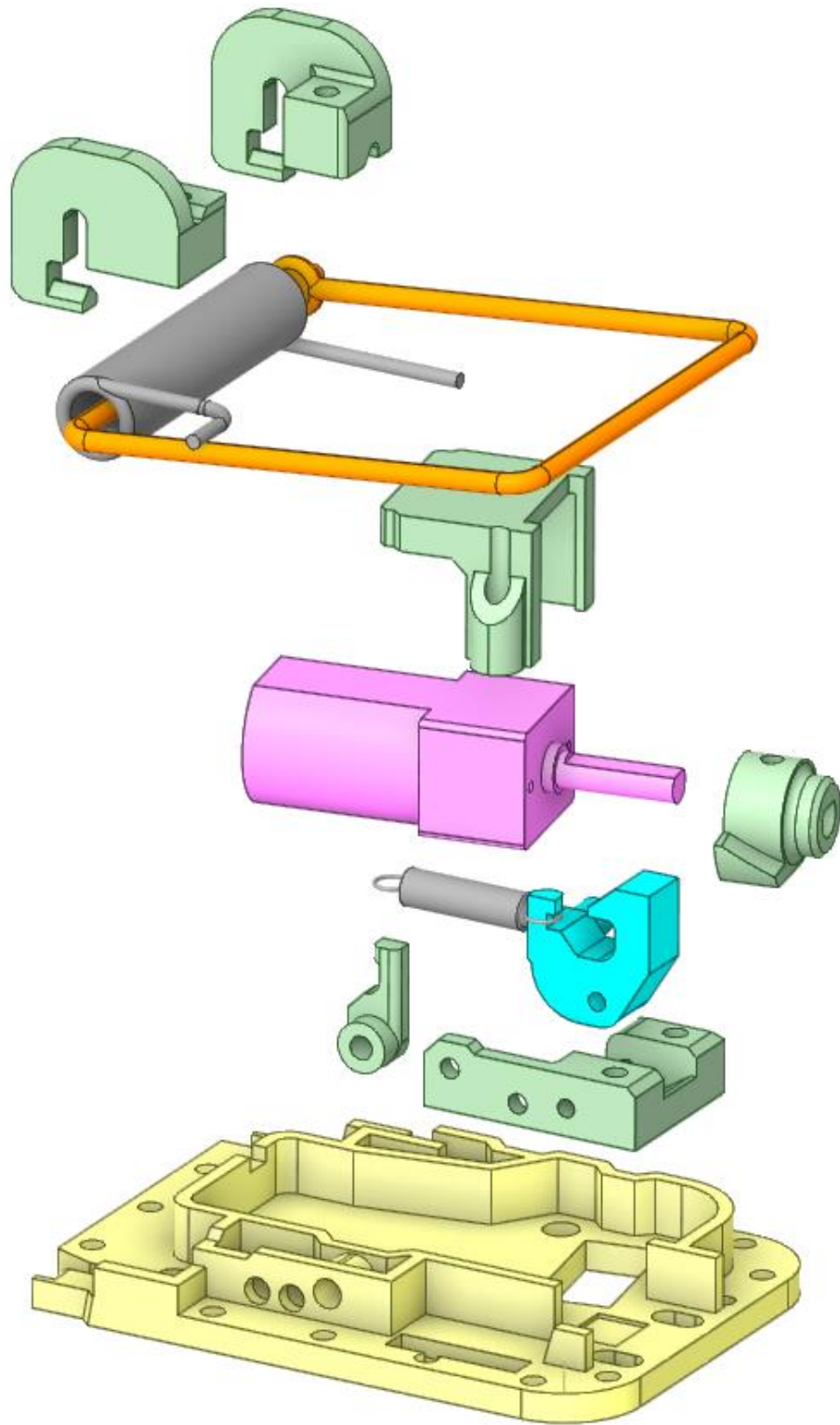

Release mechanism – Pre-release

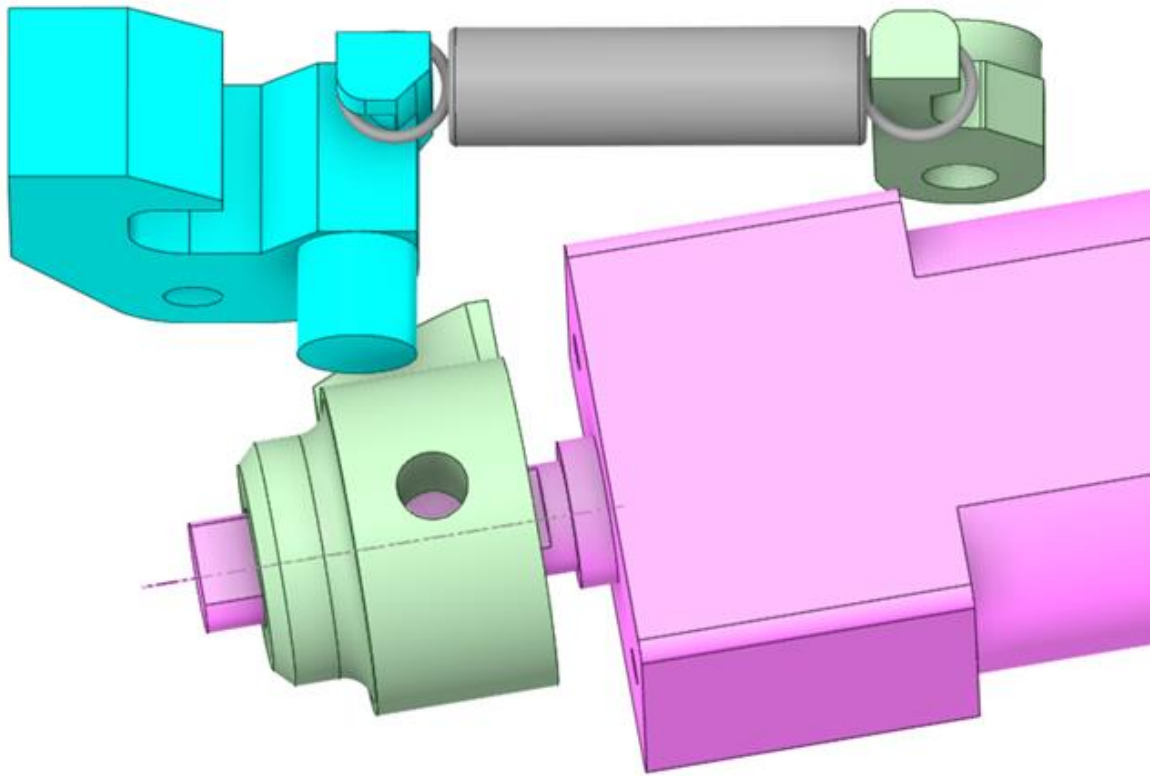

Release mechanism – Post-release

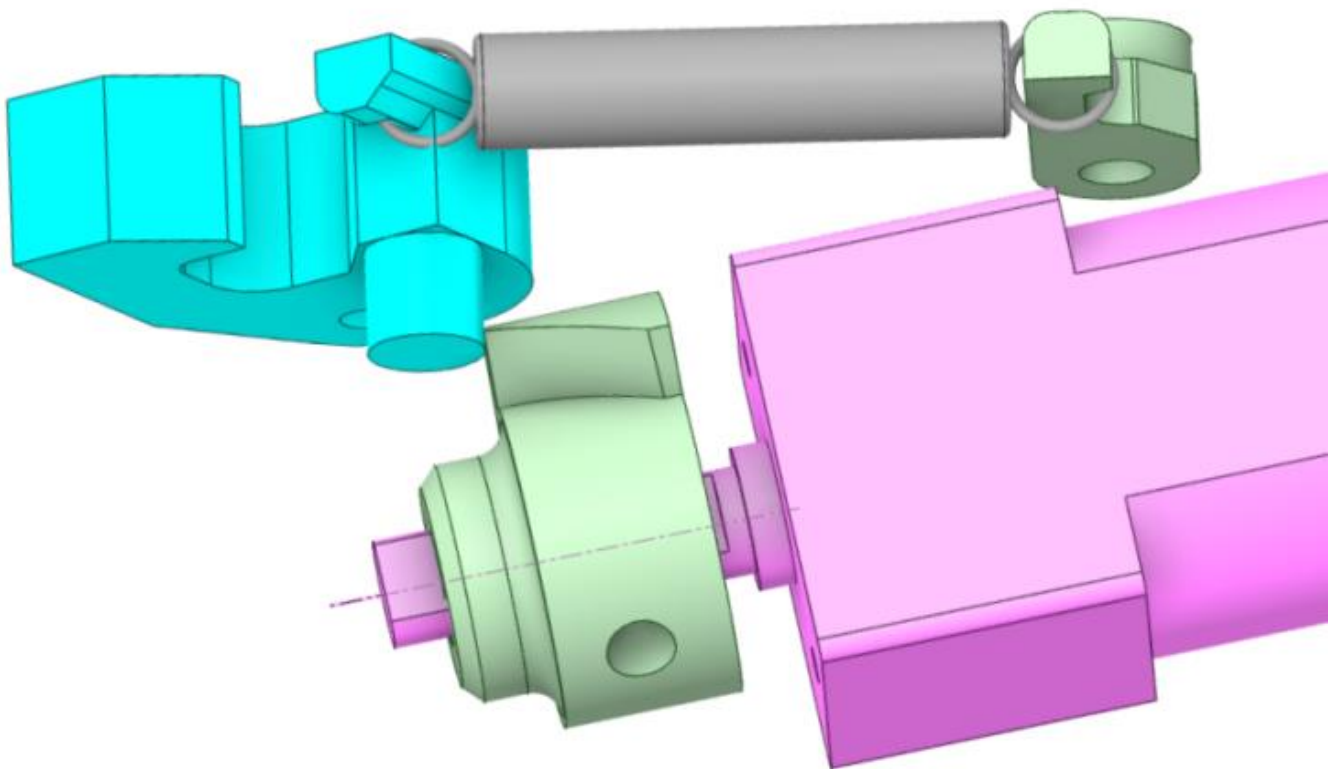

Fabrication notes:

The parts, except for the base and latch base, will need to be rotated 90 or 180 degrees to lay on the bed to eliminate the need for supports.

The parts, HingeRight and HingeLeft, should be printed with 100% infill and the other parts with 50% infill.

The horizontal hole through the latch and latch base may have to be enlarged with a 1/16" drill to accommodate the pivot pin.

Victor Mousetrap

The two holding staples can be pried up to free the rectangular ring "hammer" with its torsion spring. As shown in the photo, the wire of the torsion spring, which applies force against the hammer, should be bent with pliers. This adds more space between it and the hammer segment and also secures it to the hammer. This is the most difficult task of the project because the spring wire is hardened, but with 2 pliers it can be done.

BOM (Bill of Materials)

Line	Qty	Type	Description	Part Num	Price
1	5	Screw	#2 3/8"L RoundHead Phillips BluntSheetMetal 18-8SS	92525A118	\$5.97(100)
2	2	Screw	#4 3/8"L RoundHead Phillips BluntSheetMetal 18-8SS	92525A205	\$5.30(100)
3	1	Screw	Set 4-40 1/8"L FlatTip 316SS	92158A119	\$4.25(10)
4	1	Pin	1/16" 9/16"L SpringPin Slotted 18-8SS	92373A110	\$9.50(100)
5	1	Spring	0.5"L 0.125"OD 0.014"Wire 2.4lbf/in Extension LoopEnds Steel	9654K941	\$12.30(12)
6	1	Motor	6V 150RPM N20 3mmShaft	B07SQ4TV2T	\$6.99(1)
7	1	printPLA	Base		
8	1	printPLA	HingeLeft		
9	1	printPLA	HingeRight		
10	1	printPLA	MotorMount		
11	1	printPLA	ExtensionSpringHolder		
12	1	printPLA	MotorCam		
13	1	printPLA	Latch		
14	1	printPLA	LatchBase		



DC 6V 150RPM N20 Mini Metal Gearwheel Gear Motor 3mm Shaft for Robot Wheel DIY Toys

Brand: Hxchen

5.0 ★★★★★ (9) | Search this page

Amazon's Choice

\$6⁹⁹

[Price history](#)

Pay \$6.99 \$0.00 after using available Prime Visa rewards points.

prime Tomorrow

FREE Returns

Size: 150RPM

150RPM \$6.99 FREE Delivery Tomorrow	30RPM \$7.99 FREE Delivery Tuesday	60RPM \$7.49 FREE Delivery Tuesday	200RPM \$6.99 FREE Delivery Tuesday
---	---	---	--

300RPM \$7.69 FREE Delivery Tuesday	500RPM \$7.49 FREE Delivery Tuesday	100RPM \$7.49 FREE Delivery Tuesday
--	--	--

Brand: Hxchen
Model Name: gear

[Click to see full view](#)

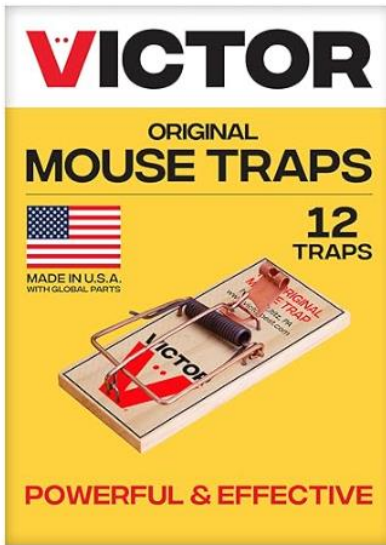

Victor Mouse Traps M150-12, Metal Pedal, Sustainably Sourced FSC Wood, Wooden Mouse Traps - Pack of 12

[Visit the Victor Store](#)

4.2 ★★★★★ (24,162) | Search this page

Amazon's Choice

20K+ bought in past month

-12% \$10⁶⁹ (\$0.89 / count)

List Price: ~~\$12.14~~ | [Price history](#)

Pay \$10.69 \$0.80 after using available Prime Visa rewards points.

prime Tomorrow

FREE Returns

Style: 12 Metal Pedal Traps

12 Metal Pedal Traps \$10.69 (\$0.89 / count) \$12.14 FREE Delivery Tomorrow	12 Plastic Pedal Traps \$15.27 (\$1.27 / count) FREE Delivery Tomorrow	20 Traps \$18.45 (\$0.92 / count) FREE Delivery Tomorrow	See 1 options with no featured offers
---	---	---	---------------------------------------

Brand: Victor

[Click to see full view](#)

