

Anodizing and Dye Tanks

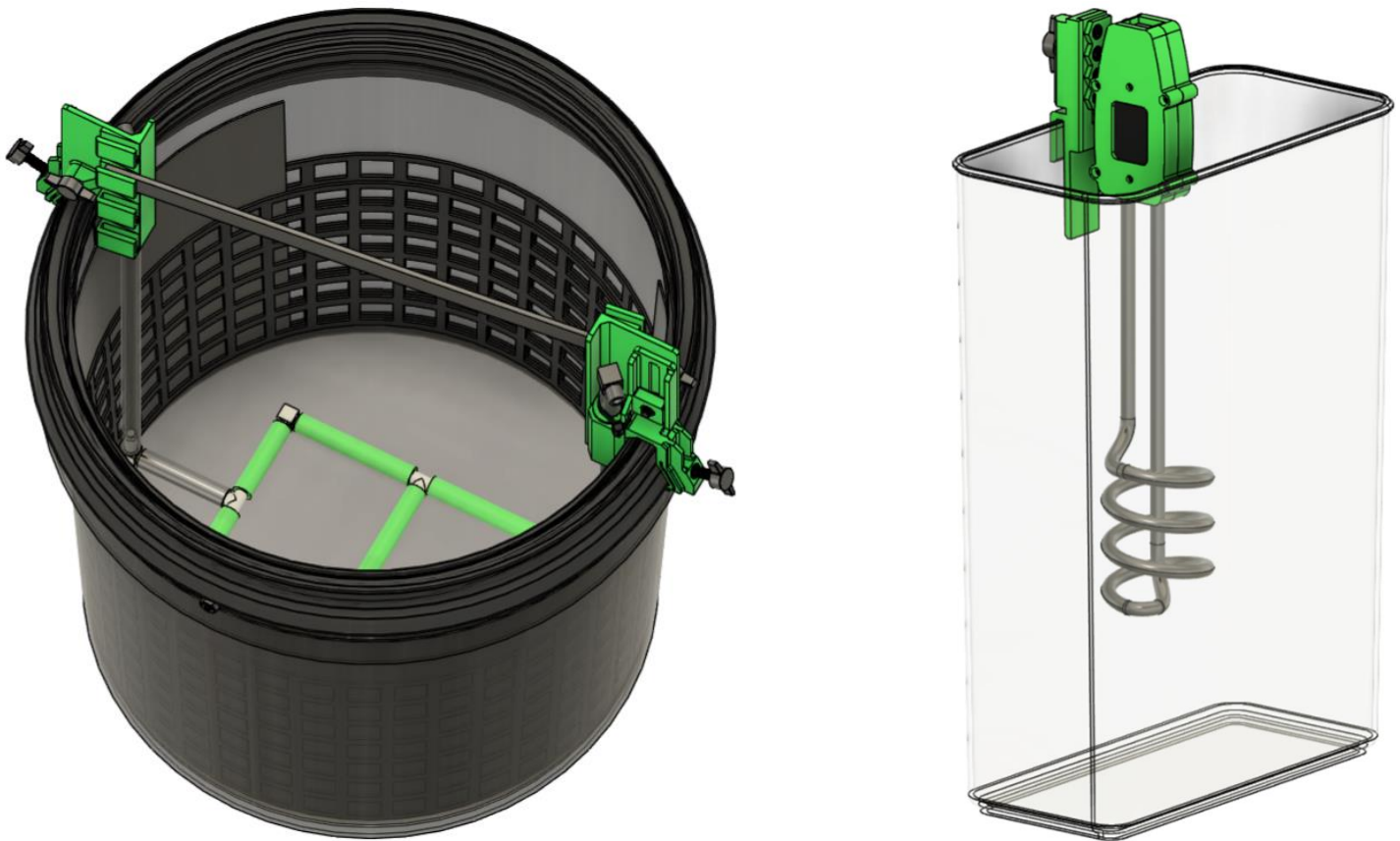

Partially filled tank. Note that bar support and bubbler tube is from an earlier design.

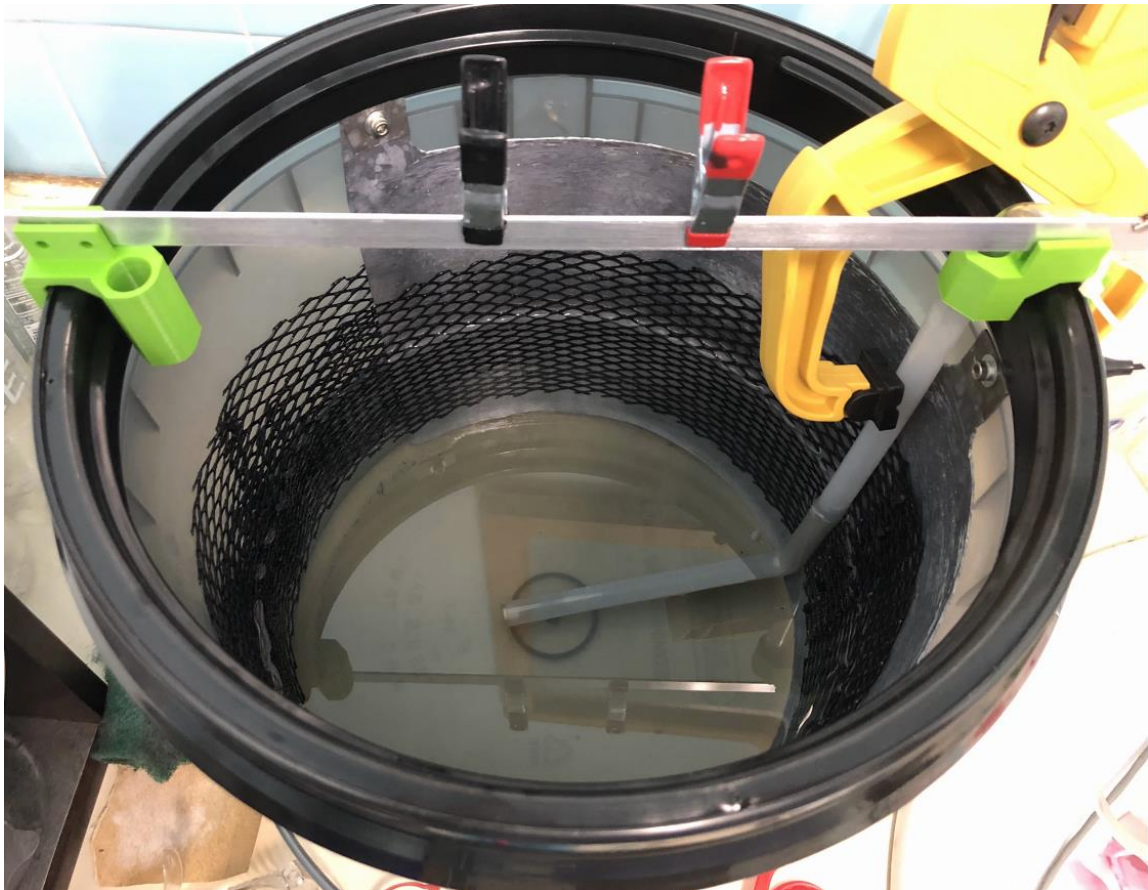

Contents

The anodyzing process	3
Bar supports	4
Bubbler assembly at bottom of bucket.....	5
Lead cathode mounting.....	5
Lead cathode cutting.....	6
Sulfuric acid bath	10
Sulfuric acid bath mixing	13
The dye bath	16
Part surface preparation.....	18
Attaching parts to the anode bar	19
Cleaning the parts	21
Sodium Hydroxide (NaOH) bath.....	22
Desmutting.....	23
Anodyzing.....	Error! Bookmark not defined.
Neutralizer bath	26
Dying	27
Sealing	28
Anodyzing worksheet and checklist	29
BOM (Bill Of Materials) – Anodyzing Tank.....	30

The anodizing process

Aluminum does not corrode as steel does due to a natural aluminum oxide layer that forms on the aluminum surface. The anodizing process increases the thickness of the aluminum oxide layer to enhance corrosion resistance and harden the surface. If there is no interest in adding a color to the aluminum, this can be considered **clear anodizing**.

For many products, the anodizing process is performed primarily for aesthetics to color the aluminum surface. Coloring aluminum using anodizing is more rugged compared to painting. Note that only aluminum and, less commonly, titanium can be anodized. Other metals cannot be anodized and can only be painted or plated.

For a colored surface, the process includes the anodizing step, where parts are suspended in a solution of sulfuric acid and a current is run through the parts and the bath. The current and time (often an hour or more) is carefully controlled to increase the aluminum oxide layer. This control also produces a surface with microscopic pores. When the part is soaked in a dye after the anodizing process, the dye is absorbed into the pores. It is this mechanism that results in the rugged colored surface.

The process is not easy, and many companies and people will send parts to a company that specializes in anodizing. There are many such companies, and it is tough to match the quality and consistency of their finishes. There are many people who still anodize as a hobby and there is a lot of good information on-line and there are companies that sell anodizing equipment and chemicals for the DIY market.

Caswell is likely the best known company in this space and is located in upstate New York.

Note that the process presented in this document was done with custom equipment and a bottle of red dye first purchased on Amazon.

The screenshot shows the Caswell website's product page for Anodizing Kits. At the top, the Caswell logo is on the left, and a search bar is on the right. Below the logo is a navigation bar with links for Plating Kits, Anodizing Kits, Gas Tank Sealer, Black Oxide, Polishing, Caswell™, and More. A hamburger menu icon is on the far left of the navigation bar. The main content area features a breadcrumb trail: Home / Anodizing Kits. Below this is the heading "ANODIZING KITS". Three product cards are displayed: "Anodizing Accessories" (with a color wheel image), "Anodizing Dyes - 20% OFF" (with an image of blue dye containers), and "Anodizing Kits" (with an image of anodizing equipment). At the bottom of the page, there are icons for a grid and list view, and a "Sort By: BEST SELLING" dropdown menu.

Bar supports

A bar needs to be supported over the anodizing acid bath. 3D printed parts were designed that attach to the bucket edges. They allow multiple height positions for the bar and a further slide adjustment. Parts are hung from the bar, which may need adjustment to account for changes in the liquid level in the bath.

Left side view

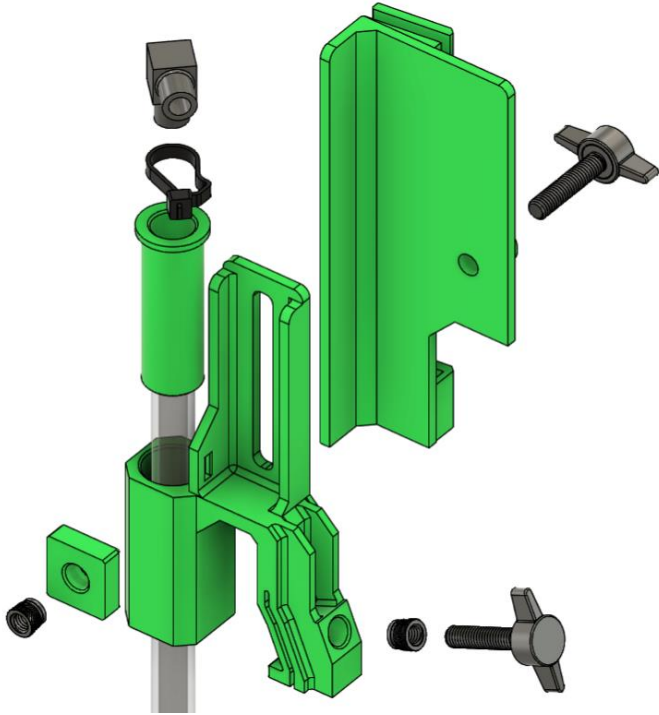

Right side view

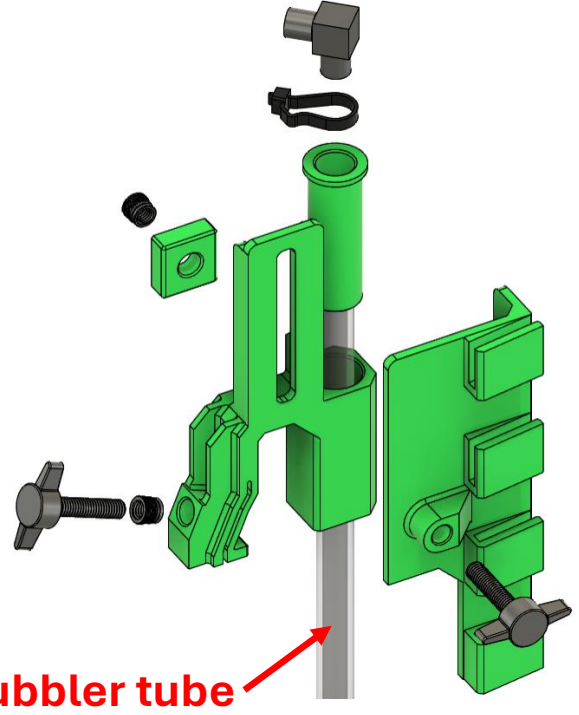

Bubbler tube

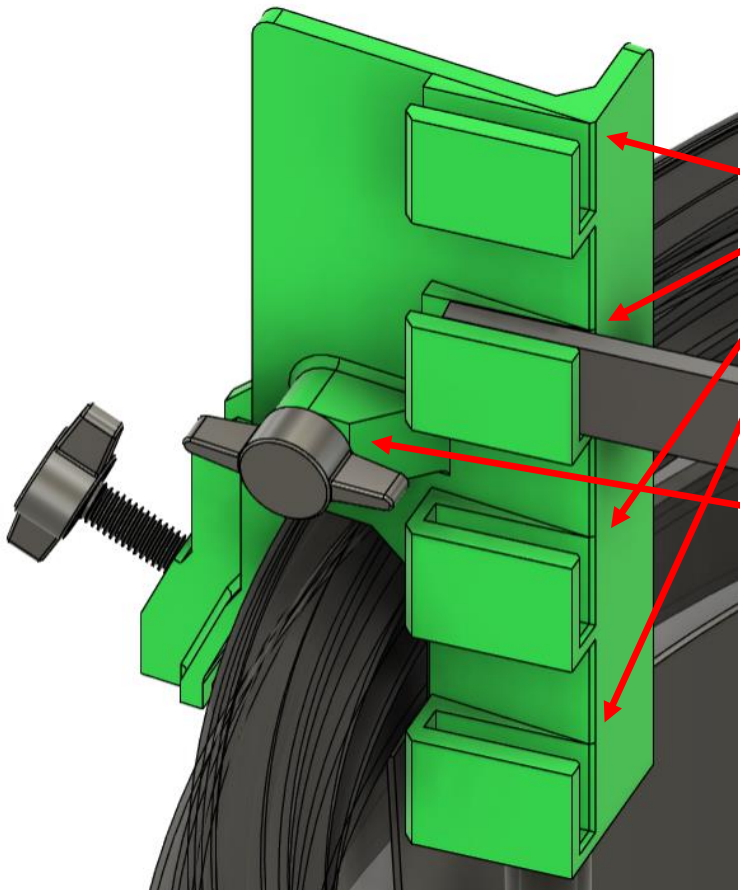

Four possible bar positions

Allows vertical positioning of bar holder

Bubbler assembly at bottom of bucket

During the anodizing process, hydrogen bubbles will form on the part surfaces. Introducing air bubbles under the parts is needed to remove the hydrogen bubbles on the part and agitate the mixture.

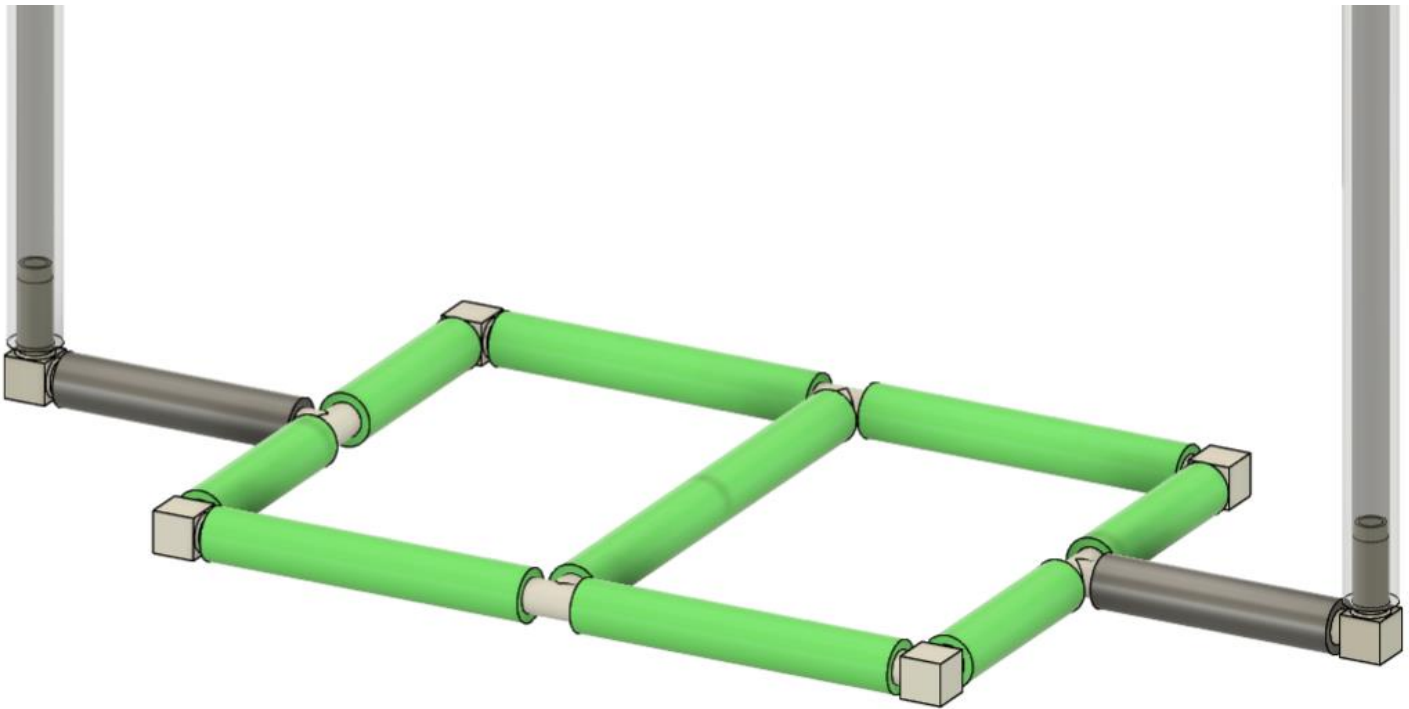

Lead cathode mounting

Because the bucket will be filled with sulfuric acid (15% by weight) steel screws will corrode. A titanium screw and nut will be used to secure one tab of the lead sheet, which will also serve as the electrical connection.

The other two tabs of the lead sheet is secured with a nylon screw and nut. The use of titanium screws and nuts is limited due to their cost.



Lead sheet tab with screw (Titanium or Nylon)

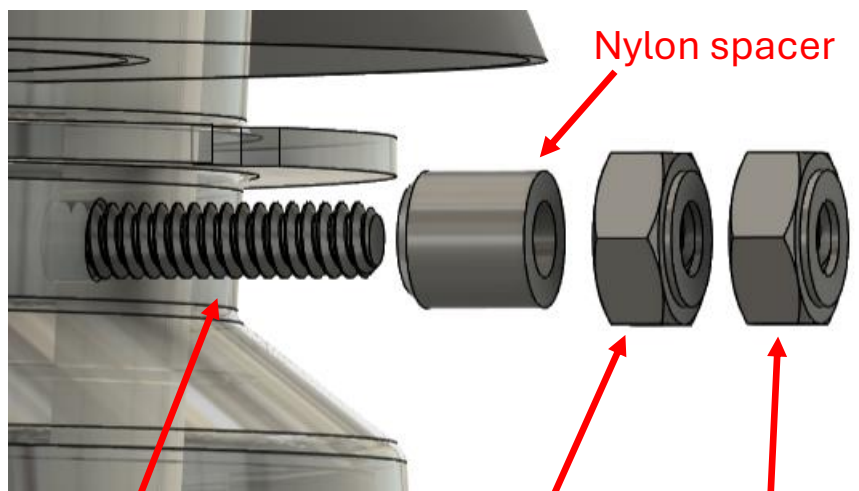

Screw threads (Titanium or Nylon)

Nut (Titanium or Nylon)

Nylon nut

Lead cathode cutting

Lead is a common cathode material. It offers a long lifetime when continuously exposed to the sulfuric acid bath and is easy to cut and form. The aluminum alloy 6063 is often used, but the more typical 6061 alloy can be used as well. With aluminum, just make sure you don't reverse polarity from the power supply. You don't want to anodize your cathode.

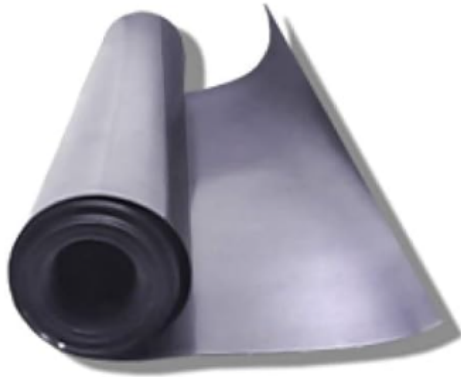

[Click to see full view](#)



KRT Distributions Lead Sheeting, Sheet Lead Rolls (1/32" x 12" x 24")

[Visit the Phillips Safety Store](#)

4.7 ★★★★★ (595) | [Search this page](#)

Amazon's Choice

\$25⁹⁵

Size: 1/32" x 12" x 24"

1/16" x 24" x 48"

\$119.00
FREE Delivery
Tuesday

1/32" x 12" x 12"

\$14.50
FREE Delivery
Thursday

1/32" x 12" x 24"

\$25.95

1/32" x 36"

\$49.95

1/32" x 12" x 36"

\$27.99
FREE Delivery
Tomorrow

1/32" x 12" x 48"

\$34.99

1/32" x 24" x 24"

\$37.99

1/64" x 24"

\$19.95

The lead sheet is unrolled and flattened. The sheet is 1/32" thick and is easy to form. It is still a little difficult to totally flatten it, as shown below.



Folder material is cut to fit in the bucket and account for the tapered surface.



The folder material template is positioned and taped to the lead. Space is left about the template to allow tabs to extend upward.

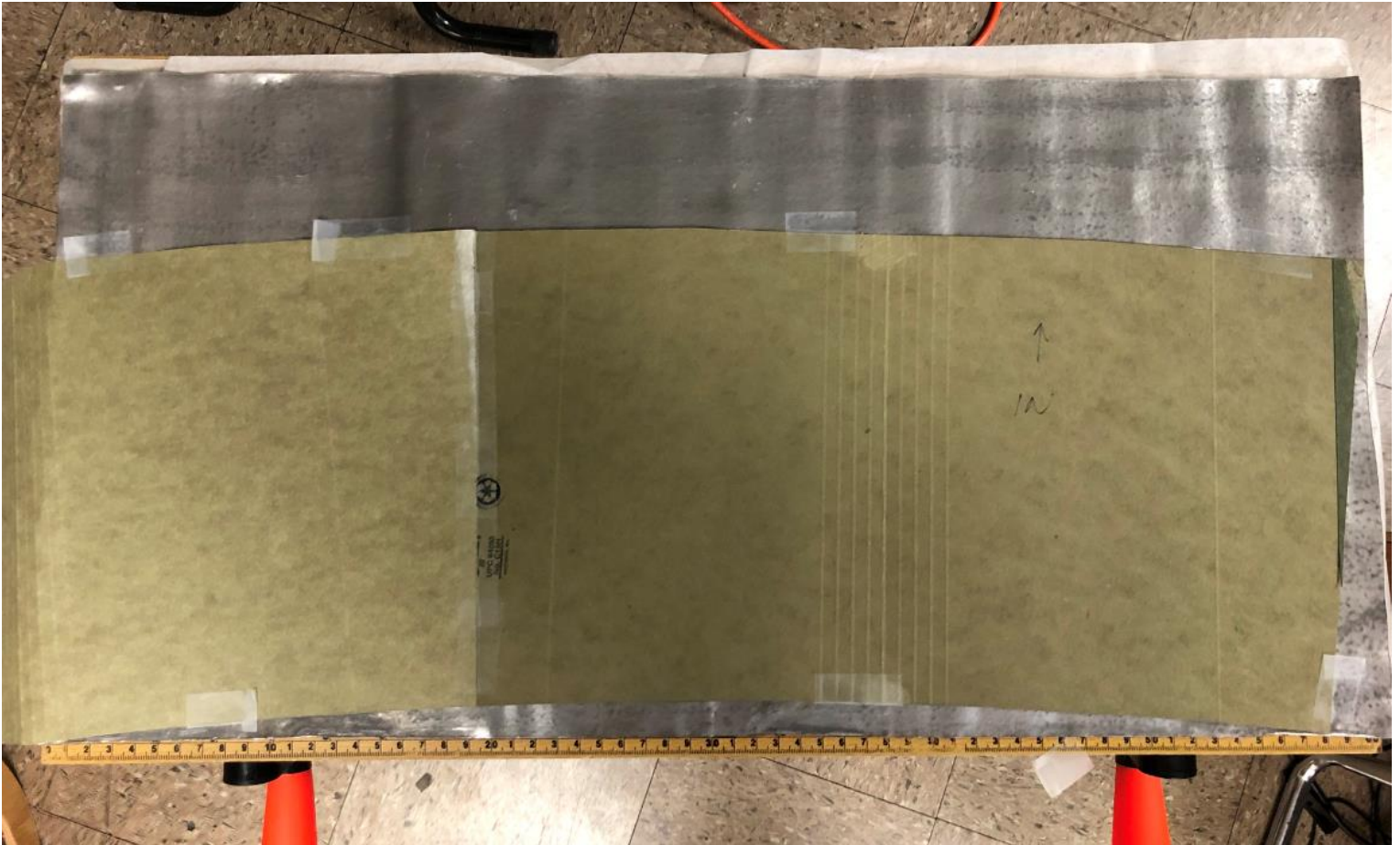

The lead is soft and thin enough to use both a scissor and exacto knife to cut the sheet to the pattern and tabs. The lead is soft enough, where one needs to be careful not to rip it where the tabs meet the main surface. The tabs are cut with fillets to help prevent the tabs from being torn off.

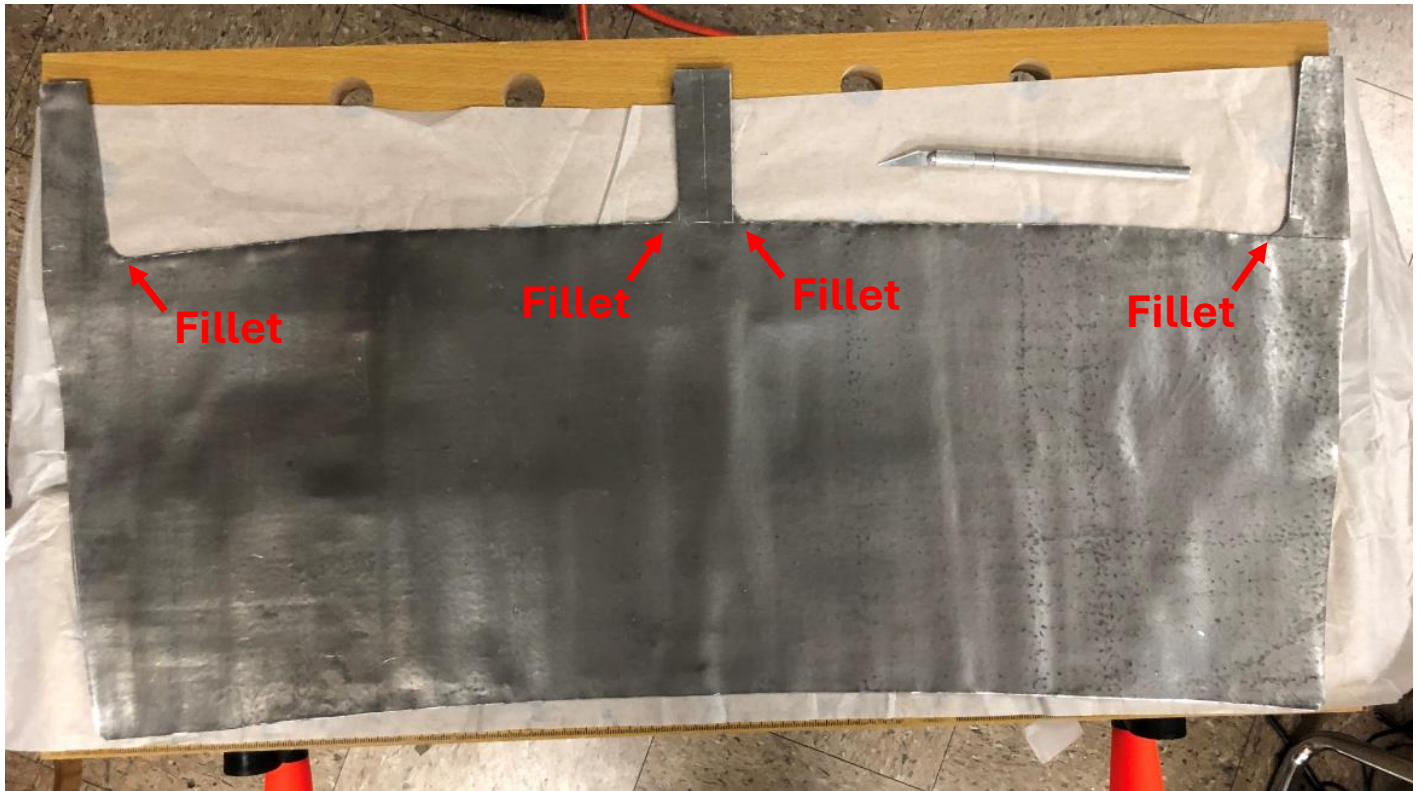

The lead is positioned in the bucket and the tabs are cut near the top lip of the bucket.

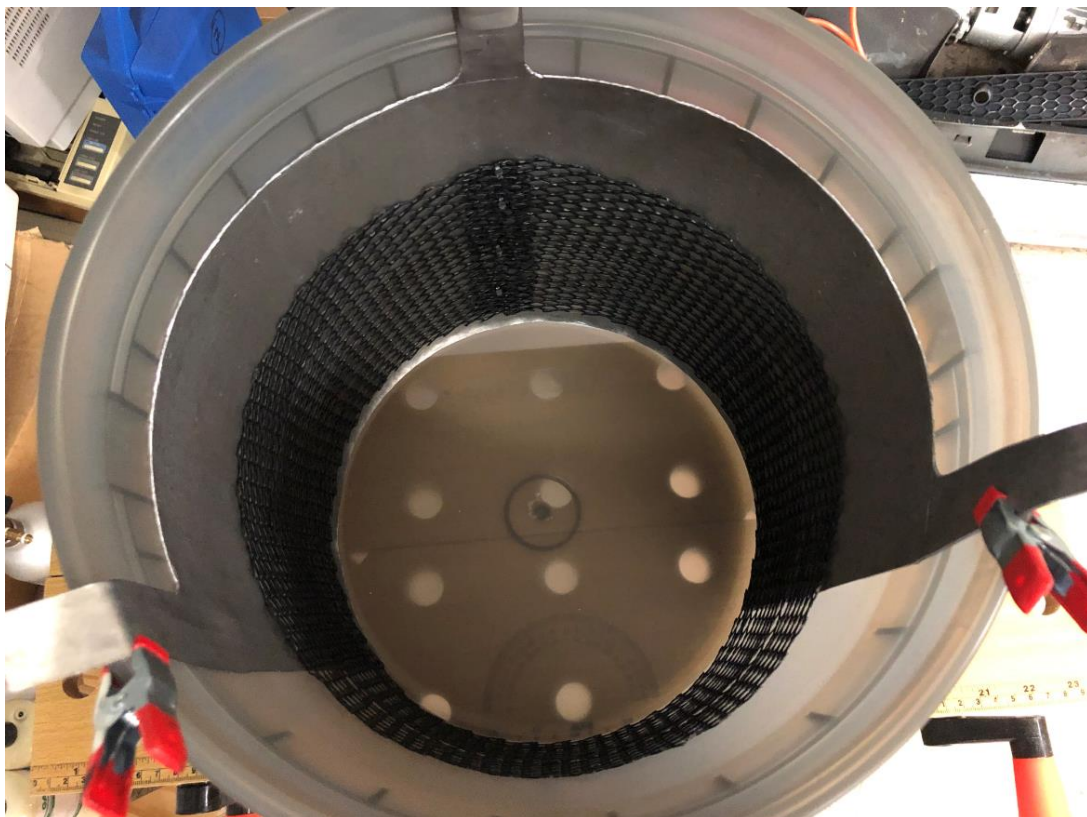

A layer of plastic mesh is placed between the bucket inner surface and the cathode to allow drainage behind the cathode. A 2nd layer is placed over the inside of the cathode to help prevent objects being anodized from shorting the circuit by touching the cathode. Plastic cable ties can be used to close up the mesh.



[Click to see full view](#)



Plastic Chicken Wire, 15.7"×106" Plastic Wire Mesh Fence, Garden Netting Fencing Barrier for Poultry, Dogs, Rabbits, Chicken and Snake Barrier, Balcony Netting for Pets, Black

Brand: HANWRAPS

4.6 ★★★★★ (41) | [Search this page](#)

Overall Pick

400+ bought in past month

\$7⁰⁹

[Price history](#)

Pay \$7.09 \$5.42 after using available Prime Visa rewards points.

prime Two-Day

FREE Returns

Sulfuric acid bath

Sulfuric acid is the most produced industrial chemical worldwide. In fact its usage in a country will track the country's GDP.

DANGER, DANGER, DANGER !

The danger depends on the concentration of the acid and is due to ability to burn skin as opposed to toxicity. That used in the anodizing bath will be 15% by weight. At this concentration, it can be poured on your hand and you won't feel it, however, you would not want it splashed in your eyes. Always wear true chemical safety goggles!

The greatest danger comes into play with the concentration of the acid before diluting it with water. A rule to address now. **When diluting sulfuric acid, always slowly add the acid to water, as opposed to adding water to acid or mixing the two quickly.** Mixing concentrated sulfuric acid and water liberates heat and one wants to avoid any water that can boil and splatter acid.

Source 1: Battery acid

The safest source for sulfuric acid is battery acid. Every gasoline or diesel car or truck has a lead acid car battery, which contains sulfuric acid. The great majority of drivers never deal with the acid in the batteries, but car part companies sell sulfuric acid as "battery acid". The concentration of this acid is about 33%. If you get this acid on your hand, it may start itching a little.

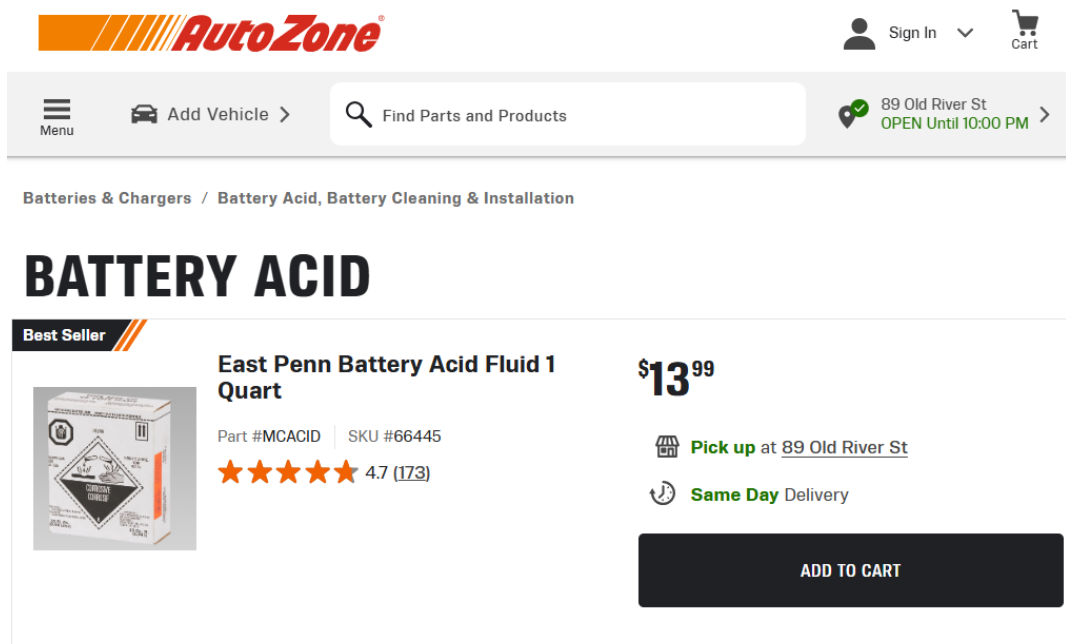

The screenshot shows the AutoZone website interface. At the top, the AutoZone logo is on the left, and 'Sign In' and 'Cart' icons are on the right. Below the logo is a navigation bar with a 'Menu' icon, 'Add Vehicle' button, a search bar containing 'Find Parts and Products', and a location indicator for '89 Old River St' which is 'OPEN Until 10:00 PM'. Below the navigation bar is a breadcrumb trail: 'Batteries & Chargers / Battery Acid, Battery Cleaning & Installation'. The main heading is 'BATTERY ACID'. A 'Best Seller' badge is present. The product listing is for 'East Penn Battery Acid Fluid 1 Quart' with a price of '\$13⁹⁹'. It includes part and SKU numbers, a 4.7 star rating from 173 reviews, and options for 'Pick up at 89 Old River St' and 'Same Day Delivery'. An 'ADD TO CART' button is at the bottom.

AutoZone Sign In Cart

Menu Add Vehicle > Find Parts and Products 89 Old River St OPEN Until 10:00 PM >

Batteries & Chargers / Battery Acid, Battery Cleaning & Installation

BATTERY ACID

Best Seller

East Penn Battery Acid Fluid 1 Quart \$13⁹⁹

Part #MCACID SKU #66445

★★★★★ 4.7 (173)

Pick up at 89 Old River St

Same Day Delivery

ADD TO CART



\$11.99

DieHard Powersports Battery Acid, 1 Liter - Used to fill serviceable batteries

Part # CYCLE ACID Excluded from discounts

★★★★★ (3 reviews)

30 Day Replacement If Defective



\$35.99

EP CQ DieHard Battery Acid



Part # CYCLE ACID Excluded from discounts

★★★★★ (32 reviews)

30 Day Replacement If Defective

Up To 20% Off! Code POURIN20 Online Only. Exclusions apply. Ends 3/30.

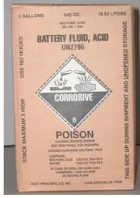
- Brand
 - NAPA (3)
- Container Size
- Engine VIN Codes
- Categories
- Price Range

	<p>NAPA Batteries Battery Acid 5 gal</p> <p>★★★★★ 5.0 (2)</p> <p>Part #: BAT 9000</p>	<p>\$45.99 / each</p> <p>Out of Stock</p> <p>Qty: <input type="text" value="1"/> Out of Stock</p>
	<p>NAPA Batteries Battery Acid 6 Quart (US)</p> <p>★★★★★ 4.6 (5)</p> <p>Part #: BAT 9002</p>	<p>\$23.99 / each</p> <p>Out of Stock</p> <p>Qty: <input type="text" value="1"/> Out of Stock</p>

Source 2: Drain opener

Lowes and True Value sell sulfuric acid based drain opener, which is a common industrial grade with a concentration of 93%. Note that most drain cleaners are based on sodium or potassium hydroxide. Home Depot does not sell a sulfuric based drain cleaner.

This concentration is nasty! If you get a small drop on your hand it will start burning in a few seconds. I am surprised that a retailer would sell acid at this concentration. The mechanism of burning is the acid ripping the water out of your cells.

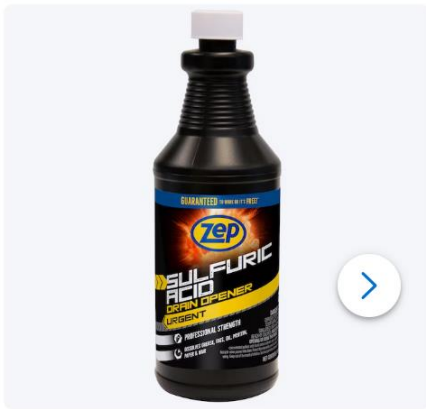

1k+ bought last week

Zep Sulfuric Acid Drain Opener 32 Ounce(s) Drain Cleaner Pour bottle

Item #1554633 | Model #ZUSADO32

Shop Zep

★★★★☆ 4.2 473

\$11^{.18}

Pickup within 3 hrs 12 available	Shipping Wed, Apr 1 40 available	Fast Delivery Tomorrow 56
---	---	--

[Departments](#)
[Deals](#)
[DIY Projects & Ideas](#)

[Home](#) / [Plumbing Supplies](#) / [Drain Openers & Septic Tank Treatments](#) / [Chemical Drain Openers & Cleaners](#) / [Drain Op](#) / [Rooto 32 Oz. Professional Drain Opener](#)

Rooto 32 Oz. Professional Drain Opener

Model #1071 | Item #405175 | UPC 00037904107122 ★★★★☆ [Write the first review](#)

Shop Rooto



\$9.79

In-store price may vary. stores .

Same-day Pickup

Call for availability
(201) 768-7759



Sulfuric acid bath mixing

The recommended concentration of sulfuric acid in water is **15% by weight**. Pure sulfuric acid is almost twice as heavy as water and thus important to note if a concentration is by weight or by volume. For anodizing only distilled water should be used. Home Depot sells 1 gallon jugs of distilled water for \$1.25.

Don't mix the acid right before anodizing. The anodizing mix should be between 68°F and 72°F. When the acid is mixed, the liberated heat will increase the temperature and then one must wait until the temperature drops. One trick to help with this is to keep some frozen bottles in the freezer, which can be added as needed. First partially fill (about 15%) them with screws or nuts so they don't float in the acid solution. Sparkling Ice seltzer bottles work well.

Note that over time water will evaporate from the bath leaving a higher concentration of acid. One may need to add water later on.

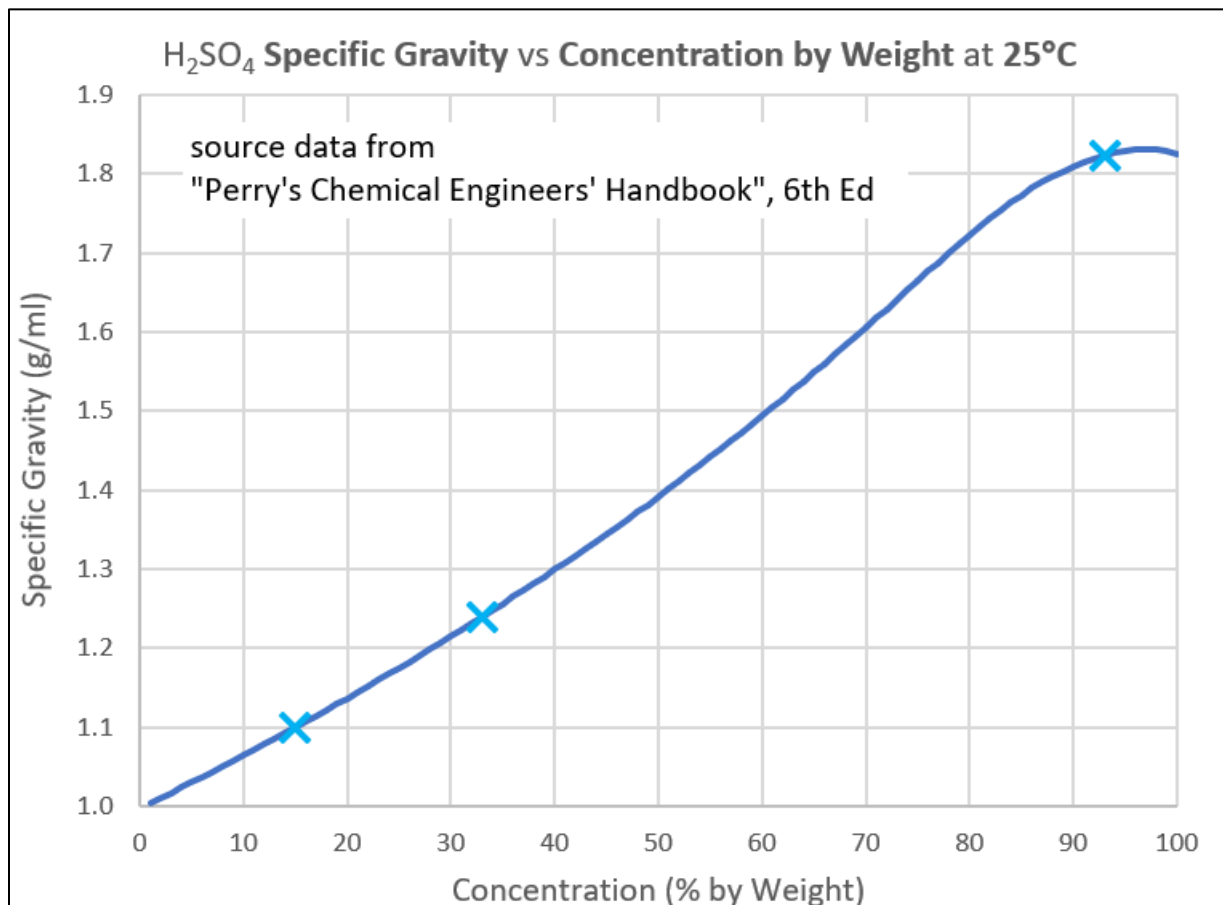

Note that over time water will evaporate from the bath leaving a higher concentration of acid. One may need to add water later on.

It's best to measure concentration using density. As seen in the **Specific Gravity vs Concentration by Weight** chart, the relationship is fairly linear up to about 90%. Using pH is

not recommended because after use dissolved aluminum can affect the pH reading. One would also have to keep a pH probe properly maintained and calibrated.

One can weigh a volume, e.g. 10ml, of water in a small graduated cylinder and then weigh the same volume of acid solution.

Another option is to float a *hydrometer* in the solution. Many are available on-line, but one needs to purchase one that measures the proper range. Many sold are for measuring alcohol concentration, which measure densities less than that of water. To measure any concentration of sulfuric acid, one would need a range of 1 to 2. Concentrated sulfuric acid has an S.G. of 1.84. There are others, such as the 2nd one listed here that are better for measuring the concentration used for anodizing of S.G. = 1.1.

Note that hydrometers are sometimes specified and marked for Degree Baume, which is a traditional density scale for industrial processes. For example, industrial grade sulfuric acid may be specified as 66° Baume, which equates to S.G.=1.84 or 93 % w/w (by weight).

$$\text{Baume} = 145 * (1 - 1 / \text{S.G.})$$

$$\text{S.G.} = 145 / (145 - \text{Baume})$$

S.G. = Specific Gravity

Specific Gravity is the density ratio to water.

The S.G. of water is 1.000

Sulfuric Acid @25C

% w/w	S.G	Baume	Molarity	Comment
98	1.84	66.0	18.4	Concentrated
93	1.84	66.0	17.4	Industry Grade
33	1.24	28.1	4.25	Battery Acid
15	1.10	13.2	1.68	Anodizing
0	1.00	0.0	0	Pure Water

Following are 2 hydrometers. The 1st has a S.G. range of 1 to 2, which would be able to measure the full range of sulfuric acid concentrations. The 2nd has a range of 9 to 21°Baume, which corresponds to a S.G. range of 1.066 to 1.250. This would allow a more accurate measurement of the desired concentration of the bath. S.G. = 1.10 (13.2 °Baume).

Note that the bath concentration does not have to be exactly 15%. This is just a commonly recommended concentration. If the bucket is not closed after use, water will evaporate over time and the acid concentration will actually increase. One would find they have to add water at times to maintain the desired concentration.



EISCO Laboratory Hydrometer - Specific Gravity, Heavy Liquids, Range 1.000 to 2.000 x 0.010 - Includes Protective Case - Eisco Labs

Visit the EISCO Store

4.4 ★★★★★ (119) | Search this page

50+ bought in past month



\$15⁷⁹

✓prime Tomorrow

FREE Returns

Save up to 21% with business pricing. Sign up for a free Amazon Business account

- Dual scale hydrometer for measuring the relative density in heavy liquids. Loaded with iron shot
- Range: 1.000 to 2.000 x 0.010
- 11" long. 0.6" diameter.
- Includes sturdy, plastic protective case
- Designed for laboratory use, but can be used in homes and shops

[Click to see full view](#)

Ask Rufus

What liquids can this hydrometer measure?



SP Bel-Art, H-B DURAC 9/21 Degree Baume Hydrometer (B61804-0100)

Visit the SP Scienceware Store

3.5 ★★★★★ (6) | Search this page

-23% \$31⁰⁶

List Price: \$40.15

✓prime Tomorrow

FREE Returns

- DURAC Baume plain form hydrometer is for use with liquids heavier than water
- Range: 9 to 21; divisions: 0.1; accuracy: 0.1 Baume
- 300mm (11.8) in length
- Individually serialized; features a metal ballast
- Tested and calibrated in our exclusive triple accredited/registered ISO/IEC 17025:2005, A2LA accredited laboratory against equipment whose calibration is traceable to NIST and DKD/PTB



[Click to see full view](#)

Ask Rufus

What liquids is this hydrometer made for?

The dye bath

The anodizing dye used should specify a temperature in the range of 115 to 140F so it must be heated. A container that seems to be a good choice is the Felli Flip-Tite 4.4qt, which can be found at Home Goods. It is meant for food storage and has a top that can be sealed. The rectangular shape can accommodate a range of parts. A good strategy is to have a few, which stay filled with certain color dyes.

A 3D printed heater mount was designed to hold a 1000W bucket heater. This will also help ensure that the heater does not touch the plastic container walls.

Be careful with the heating! 1000W of heating is a lot for a small container. Hitting the exact specified temperature is not critical. The dyeing time may only be a few minutes and a good strategy is to power the heater only until a temperature a few degrees over the target temperature is hit. Don't leave the heater on unattended. Other heaters were considered, but a low power cup heater was taking too long. One could consider a controller.

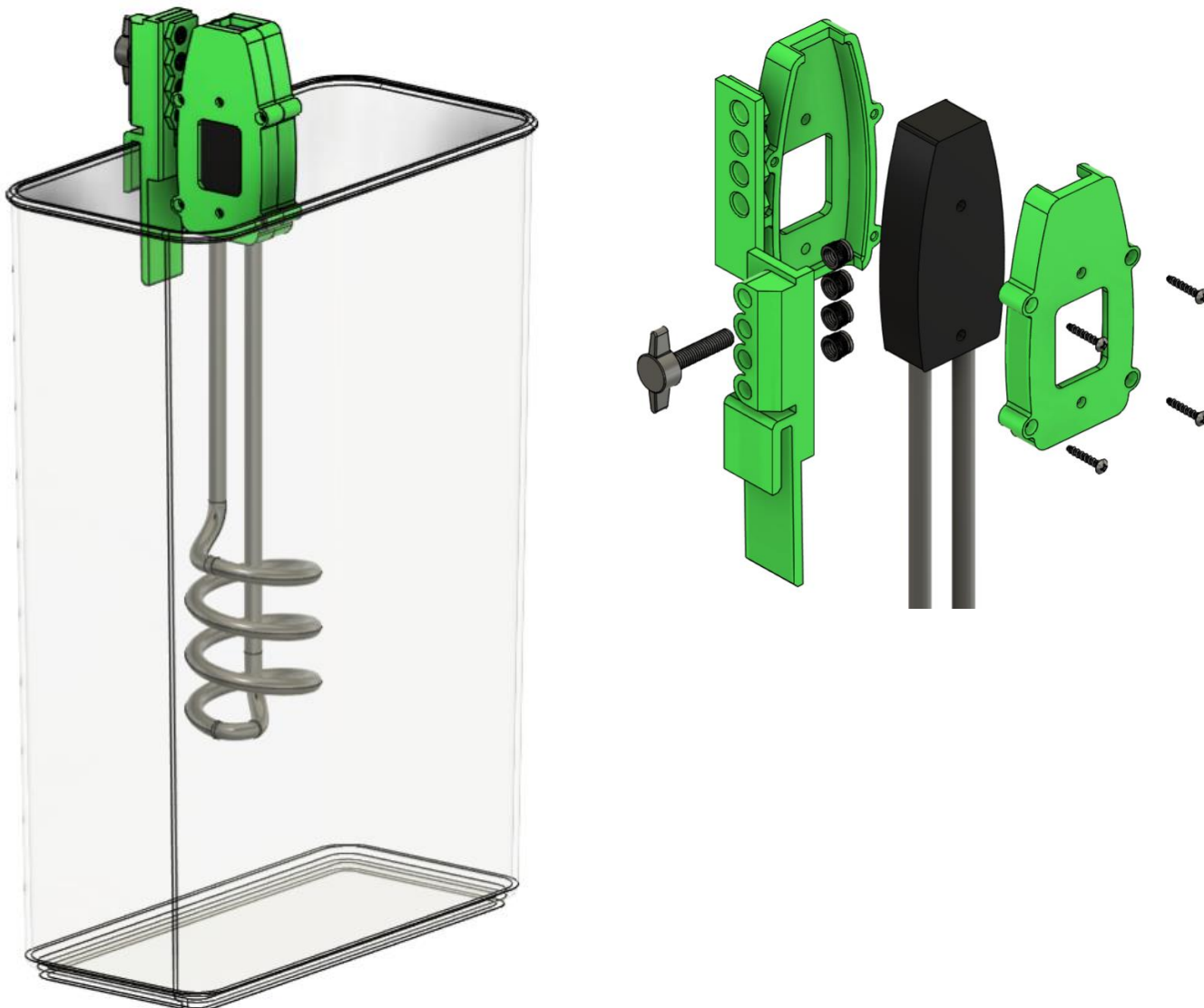

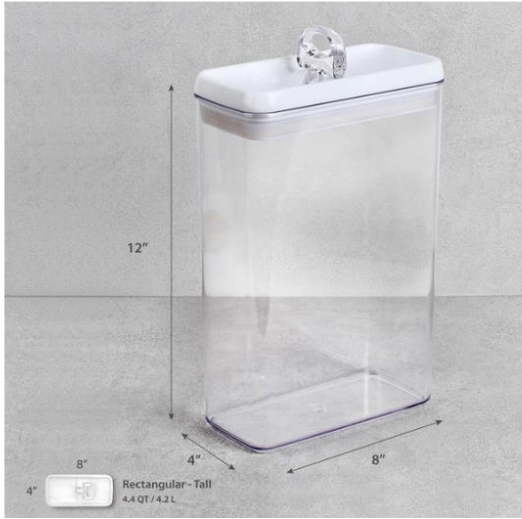

Flip-Tite 4" Rectangular-TALL 4.4QT / 4.2L

\$15.99
Color: White



Quantity

- 1 +

ADD TO CART

✓ Pickup available at 11256 Jersey Boulevard
Usually ready in 2-4 days



1000W-110V Immersion Water Heater-10in Electric Water Heater, Portable Submersible Immersion Element, Calentador de Agua Electrico Boiler Element Heating Coil for Heating Waters in Jug,Flask or Bucket

[Visit the Rugam Store](#)

4.3 ★★★★★ (280) | [Search this page](#)

Overall Pick

100+ bought in past month

-6% \$9³⁹

Typical price: \$9.99 ⓘ | [Price history](#)

✓ **prime Tomorrow**

FREE Returns ▾

Exclusive Prime price

Coupon price \$8⁴⁵ [Terms](#)

[Click to see full view](#)



TempPro TP01A Digital Meat Thermometer for Cooking Candle Liquid Deep Frying Oil Candy, Kitchen Food Instant Read Thermometer with Super Long Probe, Backlit, Lock Function (Previously ThermoPro)

[Visit the TempPro Store](#)

4.4 ★★★★★ (23,533) | [Search this page](#)

600+ bought in past month

-40% \$8⁹⁹

List Price: \$14.99 ⓘ

[Click to see full view](#)



8 VIDEOS

Part surface preparation

Various surface finishes were tried. It was found that polished aluminum resulted in the best look after anodizing. When starting an anodizing line, run some test pieces for various finishes. A good recommendation is to use sandpaper or a buffing wheel that has not been used for steel. One wants to ensure that steel particles don't become embedded in the aluminum surface to avoid any spots in the anodizing finish.

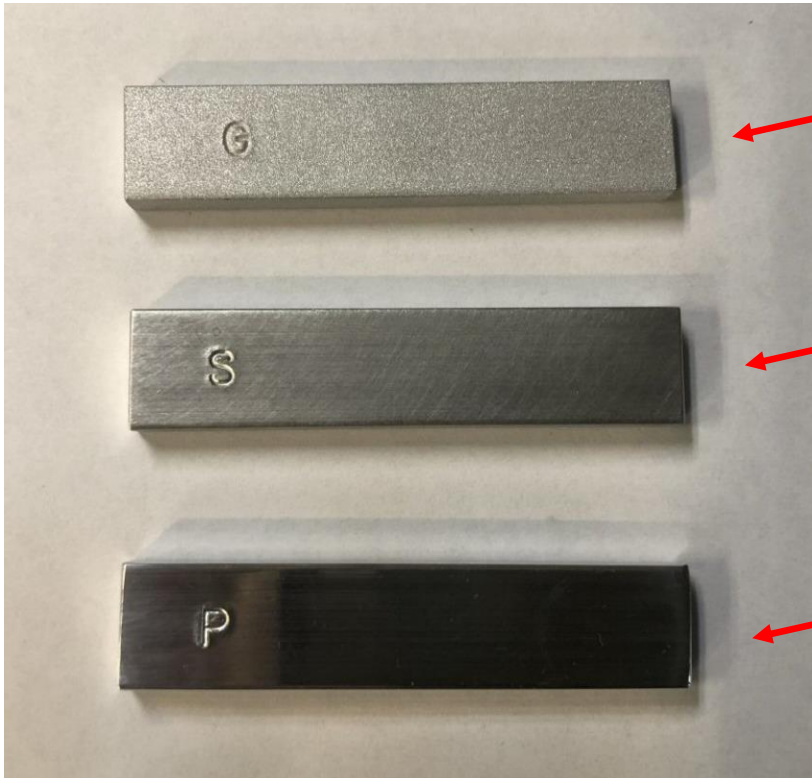

Glass bead sandblasting

Sanded with 220 grit aluminum oxide sandpaper

Polished with green rouge



Attaching parts to the anode bar

Parts being anodized must be electrically connected to the anode bar with wire so they hang down in the acid bath. This can be done using titanium or aluminum wire. Titanium wire has the advantage of being reusable and has a springiness so that a folder section can be placed in a hole. If a part has a hole, either threaded or not, this is an advantage because it can be used as the connection point.

In the anodizing industry there are companies that make all sorts of racks and accessories to hold parts in anodizing tanks.

The connection between the wire and the part to be anodized is critical. A connection may seem fine at first, but during the anodizing process the connection can degrade. One will see the voltage increase and the bubbling of the part surface stop. Then the part has to be removed from the bath and a proper connection reestablished.

Titanium wire is available on Amazon in various diameters. One annoyance of titanium is its brittleness. When using pliers to make sharp bends, the wire can crack. Lower down is an Amazon listing for silicone tapered plugs. They can be inserted into a hole with the wire to help secure them. They can also be used to plug blind holes, which is a hole (with or without a thread). This helps prevent discoloration around a hole due to liquid from a previous step becoming trapped in the hole.

Before cutting the wire, ensure there is enough for the parts to be fully submerged in the bath. The tops should be about 1 inch below the surface. There should be enough to attach securely in a hole in the part and enough to bend over the top bar over the bath.

Generic Pure Titanium Wire (20 Gauge, 10 Feet)
Brand: Generic
4.7 ★★★★★ (96) | Search this page

\$9⁰⁰

FREE Returns ▾

Size: **0.8 mm (20 ga)**

0.5 mm (24 ga)	0.8 mm (20 ga)	1.0 mm (18 ga)	1.6 mm (14 ga)
\$9.00 FREE Delivery Thursday	\$9.00 FREE Delivery Wednesday	\$10.00 FREE Delivery Sunday	\$35.90 FREE Delivery Fri, April 3

Style: **10 Feet**

1 Foot 5 Feet **10 Feet** 50 Feet

Material: Titanium
Color: Silver
Brand: Generic
Finish Type: Polished

Ask Rufus
What are common uses for titanium wire?



MECCANIXITY Silicone Rubber Tapered Plug 1.5mm to 4.5mm Solid Purple for Powder Coating, Painting, Anodizing, Plating, Sandblasting, Laboratory Use 50 Pieces

[Visit the MECCANIXITY Store](#)

4.8 ★★★★★ (5) | [Search this page](#)

\$9⁹⁹ (\$624.38 /100 cm)

Size: **1.5mm to 4.5mm**

1.5mm to 4.5mm

1.6mm to 3.2mm

1.6mm to 4.8mm

3mm to 7mm

3.2mm to 6.4mm

5mm to 9mm

It is a good idea to buy a pair of long stainless steel tweezers for fishing parts out of the bath that have detached from their wires.



JETKONG 12-Inch Fine Tweezer Tongs Long Cooking Tweezer Stainless Steel Kitchen Tweezers

[Visit the JETKONG Store](#)

4.8 ★★★★★ (832) | [Search this page](#)

Amazon's Choice

100+ bought in past month

\$8⁹⁹

✓prime Tomorrow

FREE Returns

Save up to 19% with business pricing. Sign up for a free Amazon Business account

Item Package Quantity: 1

1

2

Cleaning the parts

It is important to keep the parts super clean throughout the process. Don't handle the parts after the initial cleaning. Any oil from skin getting on the parts will affect the final finish. Wear gloves to prevent this. A good strategy is to secure the wires to the parts before cleaning.

The parts should be soaked for a few minutes in a degreasing solution. 25% diluted simple green is a good choice. As shown lower down, Caswell Plating sells degreaser powder, which will make 2 gallons of degreasing solution. This may work better than a common retail cleaner, but simple green seems to work well.

After soaking in the degreaser, the parts can be soaked or sprayed down with distilled water.



Hackensack 10PM 07601

simply green



Simple Green 32 oz. Concentrated All-Purpose Cleaner

★★★★★ (4.7 / 1052)

Model# 2710001213033

\$5.48



Simple Green 1 Gal. Concentrated All-Purpose Cleaner

★★★★★ (4.8 / 3578)

Model# 271010613005

\$9.98

Aluminum Degreaser Powder - 2lb Makes 3 Gallons

Caswell

\$34.78

Buy now and pay later with [PayPal](#). [Learn more](#)

★★★★★

(4 reviews)

[Write a Review](#)



SKU: ALDC

Sodium Hydroxide (NaOH) bath

After degreasing and washing the part with distilled water, it is dipped in the NaOH bath for 2 minutes. This will remove the existing oxidation layer. Note that if one wants to remove anodizing, even if dyed, a part can be placed in NaOH for longer. If removing a dyed anodizing finish, it should be a separate batch.

The bath solution was made by adding 33g of solid NaOH to 1000mL of distilled water. This results in a solution of about 0.8M (Molarity) or 3.3%.

100% NaOH, also called lye, is a solid and is sold as a drain opener as small pellets. It is also sold for soap making. It is hygroscopic and the pellets will start absorbing moisture from the air and seem like they are starting to melt and will start sticking together. If a pellet touches your skin it will start burning. Use gloves and chemical goggles. Measure out the pellets by weighing and then close the container. Don't pour any extra back into the container and dispose extra pellets down the drain with a good amount of water running.



sodium hydroxide

Lodi 10PM



Instant Power Crystal Lye Drain Cleaner

★★★★★ (381)

\$5⁶³



[Click to see full view](#)

ifus

Paper can be folded into a small tray to fit on a scale, as shown below. After weighing the quantity, the pellets can be poured into the distilled water tank.



NUTRI FIT Gram Scale Digital Scale 0.01g Accuracy, 500g Small Pocket Scale Jewelry Scale, Weight for Food Ounces and Grams Kitchen Scale, Mg Scale for Powder Medicine Gold Weed, Portable

[Visit the NUTRI FIT Store](#)

4.5 ★★★★★ (895) | [Search this page](#)

800+ bought in past month

-15% \$5⁴⁹

Typical price: \$6.49

prime Tomorrow

FREE Returns

Save up to 5% with business pricing. [Sign up for a free Amazon Business account](#)

Brand NUTRI FIT

Color Portable Black

Recommended Uses For Product Powder

Special Feature Accuracy to 0.01g, Auto Shut Off, Backlit Display, Low Power Indication, Portable

Desmutting

The best alloy to use for anodizing is 6063, however, the more common 6061 alloy works well. If using these alloys the desmutting step discussed here can be skipped.

The higher strength aluminum alloys, such as 2024, are a greater challenge to anodize. Due to the higher copper concentration, an additional Deoxidizer/Desmut bath, typically nitric acid, is needed before anodizing, to prevent spots on the final product. The below product, which its SDS sheet shows is Sulfuric acid 18%, Sodium nitrate 6%, worked well with 2024.

The 1st “chemical” bath used in the 6061/6063 anodizing process is the Sodium Hydroxide (NaOH) bath. If the aluminum has a high copper composition, such as 2024, a slight dark coloration will indicate that the nitric bath is needed.

After the desmutting bath the parts should be soaked or washed down with distilled water.



Sku: ALDEOX28

Deoxidizer/Desmut - 1
Quart



\$27.19

Anodizing

This is the longest step and a 90 minute anodizing time is common. This is the step where the parts are hung in the sulfuric acid bath and connected to a power supply. It is important to control the current, as opposed to the voltage, and thus a power supply with current control is necessary. It's good that most variable power supplies allows one to control the voltage or current. 10A should be fine for many applications and these power supplies are common on Amazon. Note that at high currents fumes can be created that would need ventilation.

The "720 rule" is commonly referred to in anodizing and it used to determine the time needed to achieve a certain layer thickness.

$$720 = \text{Current Density (ASF)} \times \text{Time (min)} / \text{Thickness (mils)}.$$

A good current density to use is 6 Amps per Square Foot, which corresponds to 40mA per Square Inch. A higher current density will result in fumes being created from the acid bath. The equation can be rewritten as $\text{Time (min)} = 720 * \text{Thickness (mils)} / \text{Current Density}$. Thus a 1mil (1/1000") coating thickness requires 120 minutes at 6 Amps per Square Foot. 1mil is a fairly thick coating for type 2 anodizing for dyeing. 90 minutes seems to work fine.

The power supply current setting will be based on the total surface area of all parts being anodized.

For example, the 3 parts shown earlier are 2.5" x 0.5" x 0.188" and if anodizing the 3 together, the total surface area would be 10.9 sq in. Using a current density of 40mA/sq in, the current setting should be 436mA or 0.436A. Note that this is less than 5% of the power supply capacity.

The parts should be hung in the acid bath, ensuring that they are fully submersed. Before connecting the power supply to the bath, set the voltage to 30V. This voltage is not critical. Note that the current knobs can not be at their 0 position to set a voltage.

Adjust the current knobs to their 0 position, which is fully counter-clockwise. Note that there is often a course control knob and a fine control knob for current as well as voltage.

Connect the power supply to the bath. Positive connects to the anode bar and negative connects to the lead cathode.

It is best not to hit the parts with full current at the start, but to ramp the current up over a few minutes, such as 5 minutes. Adjust the current to about 20% of the target current. Bubbles should be seen forming on the parts. If adjusting the current knob doesn't result in a current change, there could be a poor connection somewhere in the system. If running multiple parts, no bubbles forming on a part can indicate a poor connection with that part.

At this point turn on the compressor for the air bubble agitation. Over the next 5 minutes adjust the current knob each minute by another 20%. Set a timer to track the anodizing progress. Note that the voltage should not be adjusted. The voltage will change automatically depending on the current and will increase over time as the anodizing layer grows.

When the 90 minutes is finished, turn off the power supply and compressor. The parts should be removed and sprayed down with distilled water and then soaked in the acid neutralizer bath. The time period is not critical and experimentation may determine that shorter times result in adequate dying results.



DC Power Supply Variable, 0-30V 0-10A Adjustable Switching DC Regulated Bench Power Supply with High Precision 4-Digit LED Display, 5V/2A USB Port, Coarse and Fine Adjustment SPS-3010

[Visit the Jesverty Store](#)

4.5 ★★★★★ (2,103) | [Search this page](#)

Amazon's Choice

1K+ bought in past month

-15% \$49⁹⁹

List Price: \$58.99

Neutralizer bath

This neutralizer bath can be prepared using a mix of 40g baking soda (NaHCO_3) to 1000mL of distilled water.

After a spray down using distilled water, the parts should be soaked in the neutralizer bath for 5 minutes. After the 5 minute soak remove the parts and spray down with distilled water again.

We are ready for dying. Note that dying should be done soon after anodizing. Leaving the dying step for another day will allow the pores to start closing and the dye will not be absorbed as well.



ARM & HAMMER 14 oz. Baking Soda Fridge-n-Freezer Odor Absorber

★★★★★ (4.8 / 4864)

Model# 00204

\$1 00

Dying

This is the exciting step. The parts will absorb the dye fairly quickly and sometimes may only need a few minutes. If the parts are left in the dye too long, the color may be darker than desired. **It is important to read the instructions for the dye.** These will state the optimal temperature of the dye bath, typically in the range of 110 to 140F, as well as the recommended soak time. Some dyes may also need to first be activated at a high temperature before their first use.

Anodizing dyes come in either powder or liquid. Note that the 4oz bottle will make 2 gallons. A smaller amount may be needed for the container used and thus a smaller amount can be weighed to mix proportionately with the liquid amount desired.

Caswell, as well as a company named Interactivia, sell Anodizing dye. For many colors, the dye costs about \$20 for 4 oz. For some reason, some colors such as red can be twice that cost.



[Click to see full view](#)



Deep Red Anodizing Dye - 4 oz

[Visit the Caswell Store](#)

3.8 ★★★★★ (41) | [Search this page](#)













\$37³¹ (\$9.33 / ounce)

Size: **4oz - Makes 2 Gallons**

4oz - Makes 2 Gallons

US Pint - Makes 8 Gallons

Color: **Deep Red**

 \$20.23 (\$5.06 / ounce)	 \$53.12	 \$20.23 (\$5.06 / ounce)	 \$20.23 (\$5.06 / ounce)	 \$20.23 (\$5.06 / ounce)	 \$20.23 (\$5.06 / ounce)
 \$20.23	 \$20.23 (\$5.06 / ounce)	 \$20.23 (\$5.06 / ounce)	 \$37.31 (\$9.33 / ounce)	 \$20.23 (\$5.06 / ounce)	 \$20.23 (\$5.06 / ounce)

Rufus

Can this dye be used on other metals?

Does it come with instructions?

Is it safe to use indoors?

Sealing

The last step causes the pores to close to “lock in” the dye. Caswell and Interactivia sell sealers based on Nickel Acetate, which are mixed with distilled water. After dyeing the parts are soaked in a sealing bath at close to boiling 212F (100C) for 30 minutes. It’s been found that soaking a water only will also work, but using Nickel Acetate should result in a more rugged finish.



Aluminum Anodizing Pigment Dye Sealer MT-90 - Liquid Nickel Acetate

[Visit the Anodizing Dye Store](#)

4.4 ★★★★★ (70) | [Search this page](#)

\$18⁹⁵

Pay ~~\$18.95~~ \$13.64 after using available Prime Visa rewards points.

prime Two-Day

FREE Returns

Brand	Anodizing Dye
Specific Uses For Product	Industrial, Manufacturing
Material	Aluminum Sealer
Item Form	Liquid
Color	Green

[Click to see full view](#)

Anodizing worksheet and checklist

Especially if one desires to achieve consistent finish results from batch to batch, it's important to document the various parameters used. This also helps with experimentation to optimize results.

Anodizing Worksheet (Rev1).xlsx

Item description	
------------------	--

NaOH soak time		Ex: 2 mins (optional , skip if using de-oxidizer)
----------------	--	---

De-ox soak time		Ex: 1-3 mins (optional , use for Al 2024)
-----------------	--	---

SurfaceArea (in ²)	
Current (A)	
based on 6 ASF (42mA/in ²)	

Start bath temp (F)		Ex: 60-75F
Start time		
Ramp finish time		
Voltage at ramp finish		
Stop time		
Voltage at stop time		
Stop bath temp (F)		

Dye color		
Dye temp (F)		Ex: 115-140F
Dye pH		
Dye time		Ex: 10 min

Seal time		Ex: 30 min
Nickel acetate used		y or n

- clean/degrease
- ensure Ti/Al attached wires are proper length for hanging
- attach Ti/Al wires (bend out bottom hook if needed, if using Al sand connecting area)
- spray (distilled H2O)
- soak in NaOH (ex: 2 mins, **optional**, skip if using de-oxidizer) (33g NaOH to 1L H2O)
- soak in de-oxidizer (ex: 1-3 mins, **optional**, for Ai 2024)
- spray down (distilled H2O)
- soak (distilled H2O)
- ensure power supply set for 20V and 0.050A
- clean top hang bar if needed
- hang in bath and ensure parts are not touching
- set start of current ramp (ex: 100mA)
- start heating dye (~15 min before needed)
- remove parts and spray down (distilled H2O)
- soak in NaHCO3 solution (ex: 5 min) (40g NaHCO3 (baking soda) to 1L H2O)
- remove parts and spray down (distilled H2O)
- soak parts in dye (ex: 10 min)
- remove parts and spray down (distilled H2O)
- boil parts (ex: 30 min, optional use of nickel acetate)
- let parts dry

BOM (Bill Of Materials) – Anodizing Tank

Line	Qty	Type	Description	Part Num	Price
1	4	screw	Thumb 10-32 7/8"L PlasticHead TwoArm	91185A909	\$8.03(10)
2	1	screw	6-32 3/4"L PanHead Phillips Titanium	90234A215	\$5.32(1)
3	2	screw	6-32 3/4"L PanHead Slotted Nylon	92942A732	\$6.42(100)
4	1	nut	6-32 5/16"W 0.109"H Grade2 Titanium	90545A007	\$7.42(1)
5	5	nut	6-32 5/16"W 1/8"H Polypropylene	96169A452	\$6.75(10)
6	3	spacer	1/4"OD 0.14"ID 1/4"L Unthreaded Nylon Black	90176A133	\$4.78(25)
7	4	insert	10-32 0.225"L HeatSet 18-8SS	94459A757	\$8.09(5)
8	1	bar	1/8"T 1/2"W Grade2 Titanium 1ft	9139K11	\$21.50(1)
9	2	tube	1/4"ID 3/8"OD Clear PVC Hard 1ft	53945K13	\$2.72(1)
10	4	tube	BubblerTube2.36in		
11	4	tube	BubblerTube2.05in		
12	1	tube	BubblerTube4.58in		
13	2	tube	1.75in		
14	2	fitting	Elbow		
15	1	undef	3.5gal 70mil HDPE TranslucentGray HomeDepot	1005623606	\$6.98(1)
30	1	undef	BucketCompanion HDPE Black HomeDepot	266050	\$5.98(1)
16	2	printPLA	MountBase		
17	2	printPLA	MountSlider		
18	2	printPLA	SliderNut		
19	2	printPLA	MountBaseSpacer		
20	2	printPLA	CableTieUpper		
21	1	undef	OuterPlasticMesh		
24	1	undef	InnerPlasticMesh		